



Perry Hall High School Music Department *AP Music Theory Summer Packet*

4601 Ebenezer Road, Baltimore, Maryland, 21236 • 410-887-5188 • <http://perryhallband.pbworks.com>

August 11, 2015

Dear prospective AP Music Theory student,

According to my records, you are registered for the AP Music Theory class for the 2015-16 school year. At this point, you should be familiar with all the basics of music theory, notation, and fundamentals. To be sure that you will be ready to take this course, you will need to complete this packet **DUE Thursday, AUGUST 27, 2015.**

This packet contains all the material in the first chapter of our textbook. It is a college-level textbook so sometimes it can be verbose. The website, www.musictheory.net, can be a valuable resource for you as you begin your journey in the world of music theory. It is easy to follow and much more approachable than the textbook. There are also apps available for the iPhone/iPad called *Theory Lessons* (or *Theory*) and *Tenuto*. *Theory* is the app version of the above website and costs \$2.99. *Tenuto*, which costs \$3.99, is the practical application and trainer assigned to the skills learned in *Theory*. If you have an iPhone/iPad then this would be \$7 very well spent!

As you work on the readings and packet over the summer, contact me at sengel2@bcps.org if you have any questions. Don't be shy if you don't get it right away! Good luck over these next two weeks!

~Mr. Scott Engel

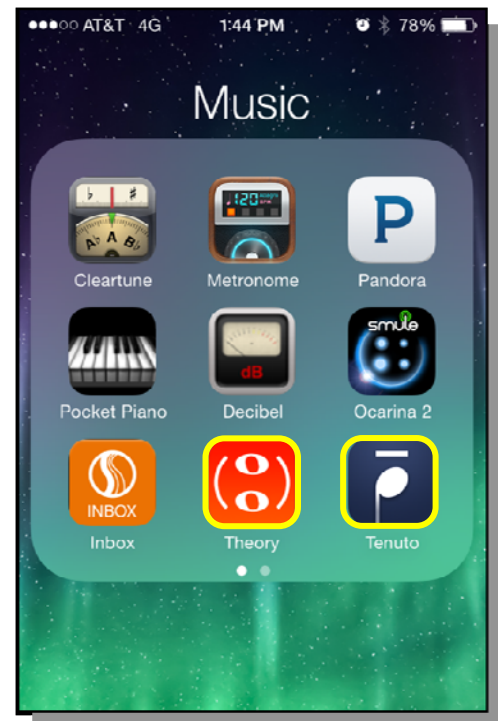

Chapter One

Elements of Pitch

The Keyboard and Octave Registers

Pitch in music refers to the highness or lowness of a sound. Pitches are named by using the first seven letters of the alphabet: A, B, C, D, E, F, and G. We will approach the notation of pitch by relating this pitch alphabet to the keyboard, using Cs as an example. The C nearest the middle of the keyboard is called middle C, or C4. Higher Cs (moving toward the right on the keyboard) are named C5, C6, and so on. Lower Cs (moving toward the left) are named C3, C2, and C1. Notes below C1 are followed by a 0, as in B0. All the Cs on the piano are labeled in Example 1-1.

Example 1-1

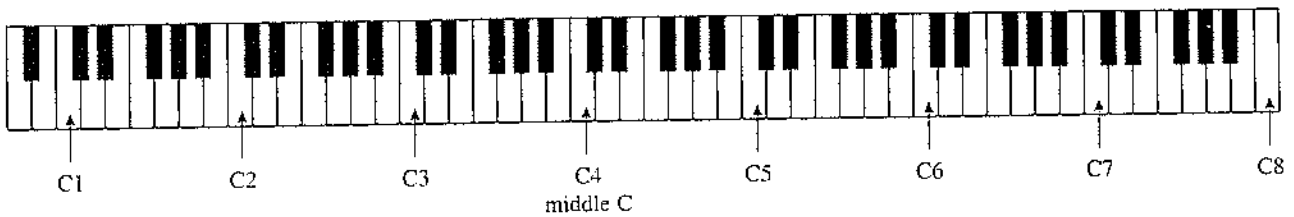

From any C up to or down to the next C is called an **octave**. All the pitches from one C up to, but not including, the next C are said to be in the same **octave register**. As Example 1-2 illustrates, the white key above C4 is named D4 because it is in the same octave register, but the white key below C4 is named B3.

Example 1-2



Notation on the Staff

Our system of musical notation is similar to a graph in which time is indicated on the X axis and pitch is shown on the Y axis. In Example 1-3, R occurs before S in time and is higher than S in pitch.

Example 1-3

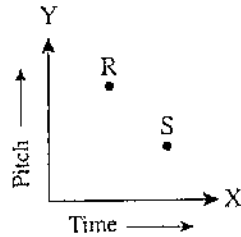

A **staff** is used in music to indicate the precise pitch desired. A staff consists of five lines and four spaces, but it may be extended indefinitely through the use of **ledger lines** (Ex. 1-4).

Example 1-4

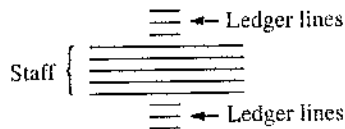

A **clef** must appear at the beginning of the staff in order to indicate which pitches are to be associated with which lines and spaces. The three clefs commonly used today are shown in Example 1-5, and the position of C4 in each is illustrated. Notice that the C clef appears in either of two positions.

Example 1-5

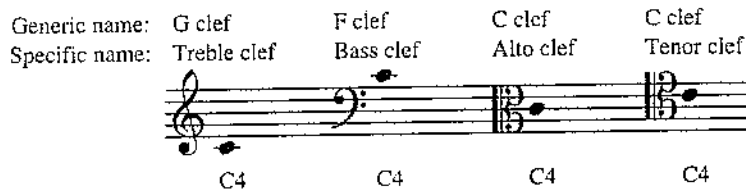

The clefs in Example 1-5 are shown in the positions that are in common use today, but you may occasionally find them placed differently on the staff in some editions. Wherever they appear, the design of the G clef circles G4, the dots of the F clef surround F3, and the C clef is centered on C4.

The **grand staff** is a combination of two staves joined by a brace, with the top and bottom staves using treble and bass clefs, respectively. Various pitches are notated and labeled on the grand staff in Example 1-6. Pay special attention to the way in which the

ledger lines are used on the grand staff. For instance, the notes C4 and A3 appear twice in Example 1-6, once in relation to the top staff and once in relation to the bottom staff.

Example 1-6

Musical notation for Example 1-6. The top staff (treble clef) contains notes F4, C4, E5, and A3. The bottom staff (bass clef) contains notes C4, F2, A3, and E4. The notes C4 and A3 are positioned on the same line in both staves, illustrating their relative positions to the staff lines.

Self-Test 1-1

(Answers begin on page 601.)

A. Name the pitches in the blanks provided, using the correct octave register designations.

Piano keyboard diagram with seven 'x' marks indicating specific pitches for identification. The marks are located on the following keys: C1, C2, C3, C4 (labeled 'ex.'), C4, C5, C6, and C7. Below the keyboard are seven numbered blanks: 1, 2, 3, 4, 5, 6, 7.

B. Notate the indicated pitches on the staff in the correct octave.

Musical staff with notes F4, B5, A4, A3, G2, D4, C4, G3, B4, C4, D3, F4. The notes are written on a grand staff (treble and bass clefs) with appropriate ledger lines to indicate their correct octaves.

Empty musical staff with notes E4, A2, F3, C6, B3, G4, B2, E5, D3, C4, B1, G3, D5, F2, D4. The notes are listed below the staff, intended to be notated on the staff in the correct octave.

Exercise 1-1 See Workbook.

The Major Scale

In this chapter you will learn about major and minor scales, the scales that form the basis of tonal music. However, there are many other kinds of scales, some of which are covered in Chapter 28.

The **major scale** is a specific pattern of small steps (called half steps) and larger ones (called whole steps) encompassing an octave. A **half step** is the distance from a key on the piano to the very next key, white or black. Using only the white keys on the piano keyboard, there are two half steps in each octave, indicated by the letter “h” in Example 1-7.

Example 1-7

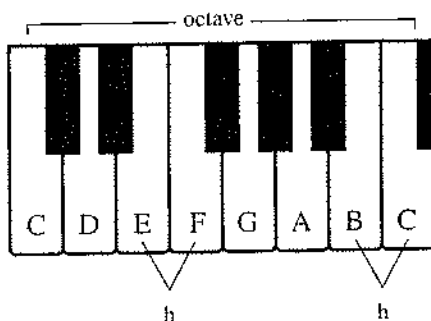

A **whole step** skips the very next key and goes instead to the following one. Using only the white keys on the piano keyboard, there are five whole steps in each octave, indicated by the letter “w” in Example 1-8.

Example 1-8

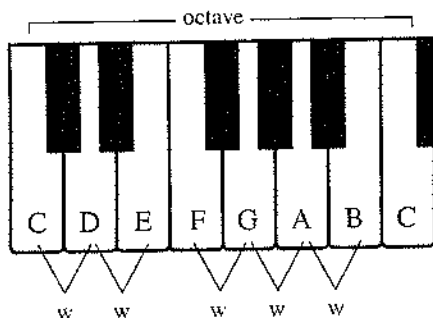

The major-scale pattern of whole and half steps is the same as that found on the white keys from any C up to the next C. In the next diagram, the numbers with carets above them (1̂, 2̂, etc.) are scale degree numbers for the C major scale.*

* Throughout this book we will refer to major scales with uppercase letters—for example, A major or A—and minor scales with lowercase letters—for example a minor or a.

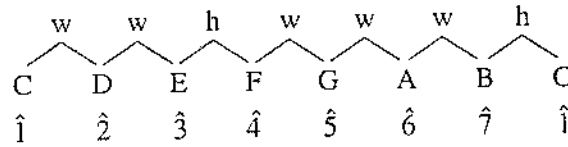

You can see from this diagram that half steps in the major scale occur only between scale degrees $\hat{3}$ and $\hat{4}$ and $\hat{7}$ and $\hat{1}$. Notice also that the major scale can be thought of as two identical, four-note patterns separated by a whole step. These four-note patterns are called **tetrachords**.

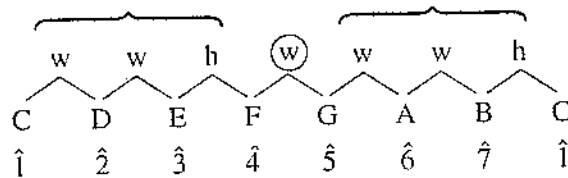

If we examine the steps on the white keys of a G-to-G octave, as in Example 1-9, we do not find the same pattern of whole and half steps that occurred in the C-to-C octave. To play a G major scale, we would need to skip the F key and play the black key that is between F and G. We will label that key with an **accidental**, a symbol that raises or lowers a pitch by a half or whole step. All the possible accidentals are listed in the following table.

Symbol	Name	Effect
⦿	Double sharp	Raise a whole step
♯	Sharp	Raise a half step
♮	Natural	Cancel a previous accidental
♭	Flat	Lower a half step
♭♭	Double flat	Lower a whole step

Example 1-9

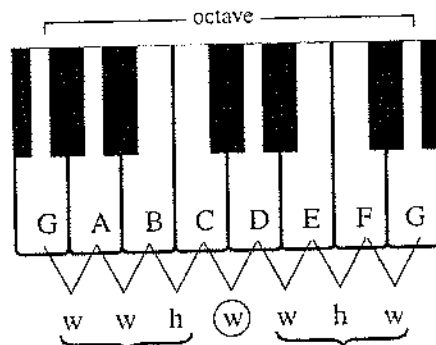

We can make our G scale conform to the major-scale pattern by adding one accidental, in this case a sharp.

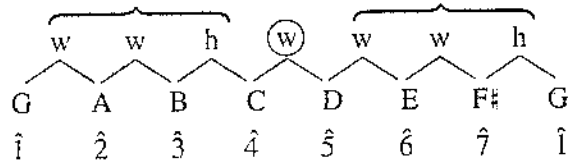

It is important to understand that major and minor scales always use all the letter names of the musical alphabet. It would not be correct to substitute a G \flat for the F \sharp in a G major scale.

The scale is written on the staff in Example 1-10.

Example 1-10



Notice that when we write or say the names of notes and accidentals, we put the accidental last (as in F \sharp or F sharp), but in staff notation the accidental always *precedes* the note that it modifies (as in Ex. 1-10).

The Major Key Signatures

One way to learn the major scales is by means of the pattern of whole and half steps discussed in the previous section. Another is by memorizing the key signatures associated with the various scales. The term **key** is used in music to identify the first degree of a scale. For instance, the key of G major refers to the major scale that begins on G. A **key signature** is a pattern of sharps or flats that appears at the beginning of a staff and indicates that certain notes are to be consistently raised or lowered. There are seven key signatures using sharps. In each case, the name of the major key can be found by going up a half step from the last sharp (Ex. 1-11).

Example 1-11

G major D major A major E major B major F \sharp major C \sharp major
 1 sharp 2 sharps 3 sharps 4 sharps 5 sharps 6 sharps 7 sharps

There are also seven key signatures using flats. Except for the key of F major, the name of the major key is the same as the name of the next-to-last flat (Ex. 1-12).

Example 1-12

Example 1-12 displays seven major key signatures on a grand staff (treble and bass clefs). The keys are arranged from left to right: F major (1 flat), B♭ major (2 flats), E♭ major (3 flats), A♭ major (4 flats), D♭ major (5 flats), G♭ major (6 flats), and C♭ major (7 flats). Each key signature is shown with its corresponding accidentals on both staves.

You may have noticed that there are three pairs of major keys that would sound exactly the same—that is, they would be played on the very same keys of the piano keyboard.

B major = C♭ major
 F♯ major = G♭ major
 C♯ major = D♭ major

Notes that are spelled differently but sound the same are said to be **enharmonic**; B major and C♭ major, for example, are enharmonic keys. If two major keys are not enharmonic, then they are **transpositions** of each other. To **transpose** means to write or play music in some key other than the original.

The key signatures in Examples 1-11 and 1-12 must be memorized—not only the number of accidentals involved but also their order and placement on the staff. Notice that the pattern of placing the sharps on the staff changes at the fifth sharp for both the treble and the bass clefs. Try saying aloud the order of accidentals for sharps (FCGDAEB) and for flats (BEADGCF) until you feel confident with them.

Key signatures are written in much the same way using the alto and tenor clefs as they are for treble and bass. The only exception is the placement of sharps in the tenor clef, as you can see in Example 1-13.

Example 1-13

Example 1-13 shows musical notation for key signatures in alto and tenor clefs. The notation includes sharp signs for the notes in the key signature, demonstrating how they are placed in the tenor clef.

Some people find it easier to memorize key signatures if they visualize a **circle of fifths**, which is a diagram somewhat like the face of a clock. Reading clockwise around the circle of fifths on the following page, you will see that each new key begins on $\hat{5}$ (the fifth scale degree) of the previous key.

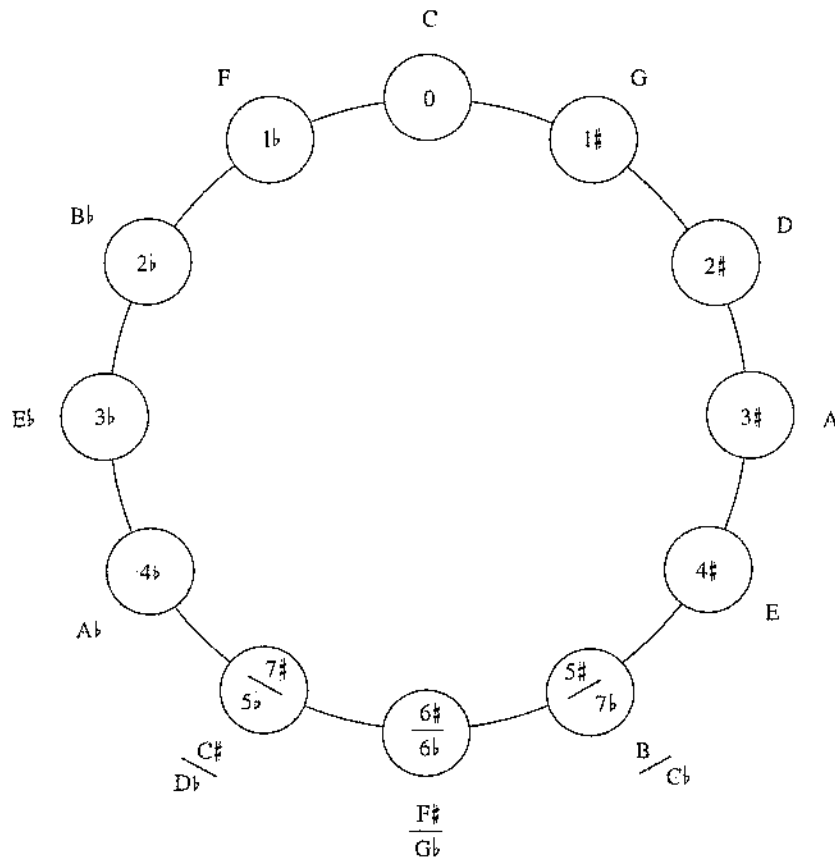

CHECKPOINT

1. Does G₃ lie below or above middle C?
2. How is a double sharp notated?
3. Half steps in the major scale occur between scale degrees _____ and _____ as well as between scale degrees _____ and _____.
4. The major scale consists of two identical four-note patterns called _____.
5. Name the 15 major keys.

Self-Test 1-2

(Answers begin on page 602.)

- A. Notate the specified scales using accidentals, *not* key signatures. Show the placement of whole and half steps, as in the example.

C major E major

D \flat major B \flat major

C \sharp major A major

F major F \sharp major

B. Identify these major key signatures.

$\frac{C}{\text{ex.}}$ major $\frac{1}{1}$ major $\frac{2}{2}$ major $\frac{3}{3}$ major $\frac{4}{4}$ major $\frac{5}{5}$ major $\frac{6}{6}$ major $\frac{7}{7}$ major

C. Notate the specified key signatures.

A major D \flat major F \sharp major B \flat major B major C \flat major D major C major

D. Fill in the blanks.

Key signature	Name of key	Key signature	Name of key
1. Three flats	___ major	8. _____	B \flat major
2. Seven sharps	___ major	9. One sharp	___ major
3. _____	D major	10. Five flats	___ major
4. One flat	___ major	11. _____	F \sharp major
5. _____	A \flat major	12. _____	C \flat major
6. _____	B major	13. Four sharps	___ major
7. Six flats	___ major	14. _____	A major

E. Fill in the blanks, using the example as a model.

Ex.	Major key	Key signature	Scale degree	Is this note
	C	0♯/0♭	3̂	E
1.			2̂	F
2.	D♭		5̂	
3.	G			F♯
4.	B		3̂	
5.	A♭			F
6.		7♭		F♭

Exercise 1-2 See Workbook.

Minor Scales

Musicians traditionally practice and memorize three minor-scale formations, although these are a simplification of how minor keys actually work, as we will see in Chapter 4. One of these is the **natural minor scale**. You can see from the following illustration that the natural minor scale is like a major scale with lowered 3̂, 6̂, and 7̂.

C major	C	D	E	F	G	A	B	C
Scale degree	1̂	2̂	3̂	4	5̂	6̂	7̂	1̂
c natural minor	C	D	E♭	F	G	A♭	B♭	C

Another minor scale type is the **harmonic minor scale**, which can be thought of as major with lowered 3̂ and 6̂ (or as natural minor with a raised 7̂).

C major	C	D	E	F	G	A	B	C
Scale degree	1̂	2̂	3̂	4	5̂	6̂	7̂	1̂
c harmonic minor	C	D	E♭	F	G	A♭	B	C

The third type of minor scale is the **melodic minor scale**, which has an ascending form and a descending form. The ascending form, shown next, is like major with a lowered 3̂ (or as natural minor with a raised 6̂ and 7̂).

C major	C	D	E	F	G	A	B	C
Scale degree	1̂	2̂	3̂	4	5̂	6̂	7̂	1̂
c ascending melodic minor	C	D	E♭	F	G	A	B	C

The descending form of the melodic minor scale is the same as the natural minor scale.

The three minor scale types are summarized in Example 1-14. The scale degrees that differ from the major are circled. Notice the arrows used in connection with the melodic minor scale in order to distinguish the ascending $\hat{6}$ and $\hat{7}$ from the descending $\hat{6}$ and $\hat{7}$. Notice that scale degrees $\hat{1}$ through $\hat{5}$ are identical in all three forms of the minor scale. This pattern of w-h-w-w-w is known as the **minor pentachord**.

Example 1-14

Natural minor



Harmonic minor



Melodic minor



Minor Key Signatures

Minor key signatures conform to the natural minor scale, no matter which minor scale type is actually in use. Looking back at Example 1-14, you can see that the natural minor scale on C requires three accidentals: B \flat , E \flat , and A \flat . The key signature of c minor, then, is the same as the key signature of E \flat major; c minor and E \flat major are said to be **relatives** because they share the same key signature. The $\hat{3}$ of any minor key is $\hat{1}$ of its relative major, and the $\hat{6}$ of any major key is $\hat{1}$ of its relative minor. If a major scale and a minor scale share the same $\hat{1}$, as do C major and c minor, for example, they are said to be **parallels**. We would say that C major is the parallel major of c minor.

The circle of fifths is a convenient way to display the names of the minor keys and their relative majors, as well as their key signatures. In the following diagram, the names of the minor keys (in lowercase, as usual) are inside the diagram.

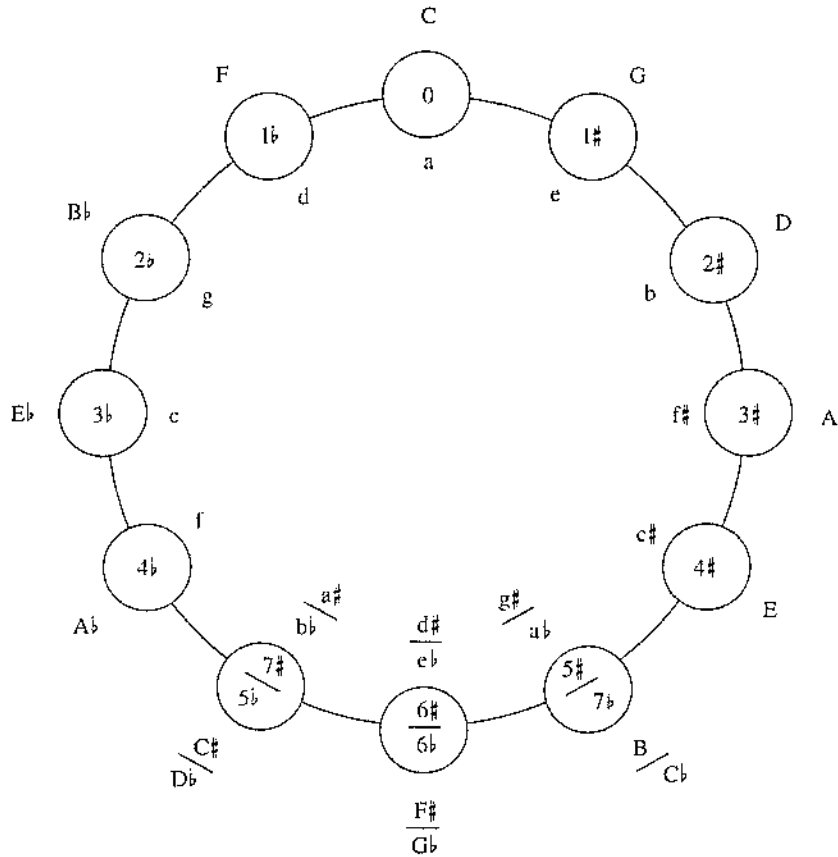

You may find it easier to learn the minor scales in terms of their relative majors, as in the preceding circle-of-fifths diagram, instead of in terms of their parallel majors, which is how minor scales were introduced on page 13. This will be most helpful regarding the keys of g#, d#, and a#, which have no parallel major forms. If you do use the relative major approach, remember that the key signature for any minor scale conforms to the *natural* minor scale and that accidentals must be used to spell the other forms. Specifically, you have to raise $\hat{7}$ of the natural minor scale to produce the harmonic minor scale and raise $\hat{6}$ and $\hat{7}$ of the natural minor scale to get the ascending form of the melodic minor scale. Example 1-15 illustrates the spellings for the related keys of F major and d minor.

Example 1-15

F major scale

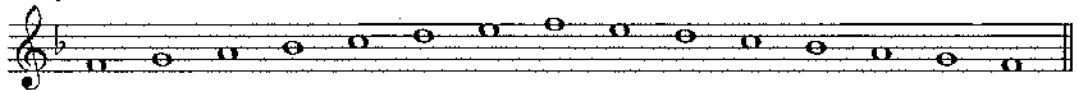

Relative minor, natural form



Harmonic minor raises $\hat{7}$

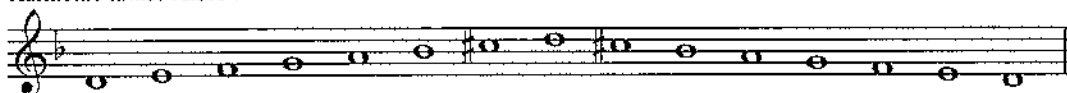

Melodic minor raises $\hat{6}$ and $\hat{7}$, ascending only



One final hint: a quick way to find any minor key signature other than $g\sharp$, $d\sharp$, or $a\sharp$ is to begin with the key signature of the *parallel* major and to add three flats and/or subtract three sharps. Examples:

Major key		Minor key	
B \flat	2 flats	b \flat	5 flats
E	4 sharps	e	1 sharp
D	2 sharps	d	1 flat

It is very important to practice faithfully all the major and minor scales on an instrument until they become memorized patterns. An intellectual understanding of scales cannot substitute for the secure tactile and aural familiarity that will result from those hours of practice.

Self-Test 1-3

(Answers begin on page 603.)

A. Notate the specified scales using accidentals, *not* key signatures. The melodic minor should be written both ascending and descending.

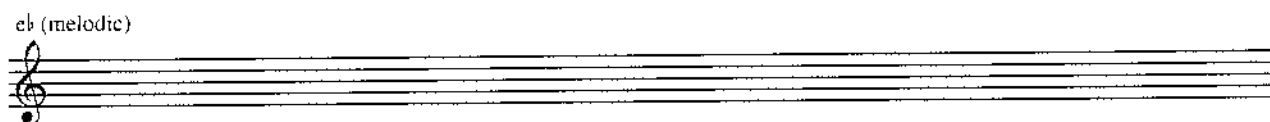
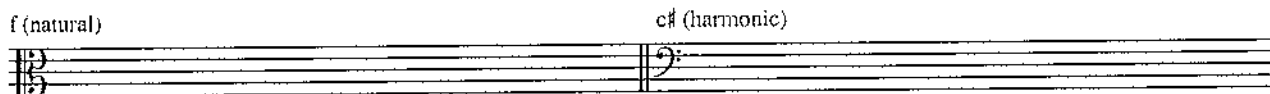
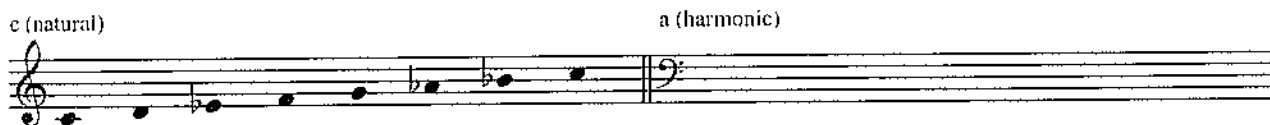

b \flat (natural) g \sharp (harmonic)

f \sharp (melodic)

B. Identify these minor key signatures.

a minor
1 minor
2 minor
3 minor
4 minor
5 minor
6 minor
7 minor

C. Notate the specified minor key signatures.

b
d
g \sharp
c
f $\sharp\sharp$
a
b $\flat\flat$
a \sharp

D. Fill in the blanks.

Key signature	Name of key	Key signature	Name of key
1. _____	d minor	8. Two flats	___ minor
2. Six flats	___ minor	9. _____	f minor
3. Four sharps	___ minor	10. _____	b minor
4. _____	f \sharp minor	11. Three flats	___ minor
5. Six sharps	___ minor	12. _____	a \flat minor
6. _____	b \flat major	13. One sharp	___ minor
7. _____	a \sharp major	14. Five sharps	___ minor

Exercise 1-3 See Workbook.

Scale Degree Names

Musicians in conversation or in writing often refer to scale degrees by a set of traditional names rather than by numbers. The names are shown in Example 1-16. Notice that there are two names for $\hat{7}$ in minor, depending on whether it is raised.

Example 1-16

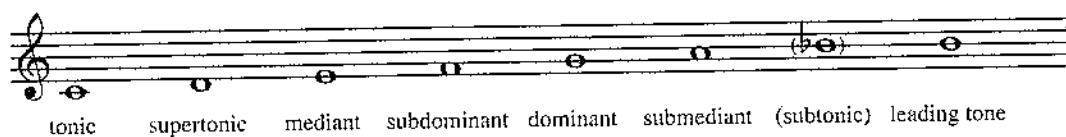

The origin of some of these names is illustrated in Example 1-17. Notice that the mediant lies halfway between the tonic and the dominant, while the submediant lies halfway between the tonic and the subdominant.

Example 1-17

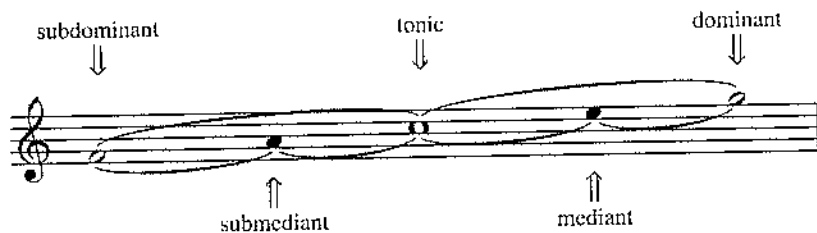

CHECKPOINT

Now is the time to start learning the scale degree names, if you do not know them already. Here are a couple of exercises that will help.

1. Translate these numbers aloud to scale degree names as fast as possible. Repeat as often as necessary until speed is attained.

$\hat{1} \hat{2} \hat{3} \hat{4} \hat{5} \hat{6} \hat{7} \hat{1} \hat{7} \hat{6} \hat{5} \hat{4} \hat{3} \hat{2} \hat{1}$

$\hat{3} \hat{5} \hat{7} \hat{6} \hat{4} \hat{2} \hat{1} \hat{6} \hat{3} \hat{7} \hat{2} \hat{5} \hat{4} \hat{3} \hat{1}$

$\hat{5} \hat{2} \hat{7} \hat{4} \hat{6} \hat{3} \hat{1} \hat{2} \hat{7} \hat{5} \hat{6} \hat{4} \hat{1} \hat{3} \hat{2}$

2. Call out or sing the scale degree names contained in each example that follows.

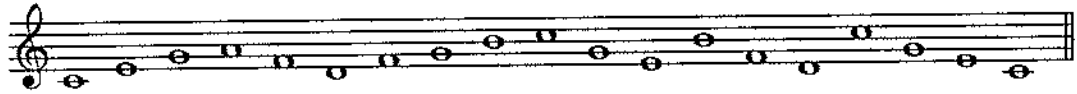

C:



G:

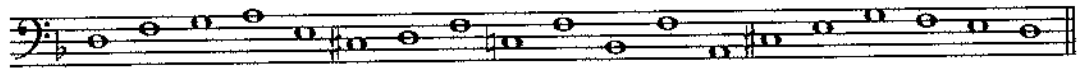

d:

Intervals

An **interval** is the measurement of the distance in pitch between two notes. A **harmonic interval** results when the notes are performed at the same time, whereas a **melodic interval** occurs when the notes are played successively (Ex. 1-18). The method of measuring intervals is the same for both harmonic and melodic intervals.

Example 1-18

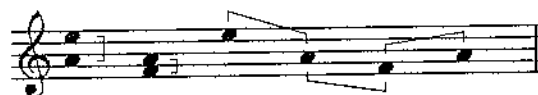

Harmonic intervals

Melodic intervals

There are two parts to any interval name: the numerical name and the modifier that precedes the numerical name. As Example 1-19 illustrates, the numerical name is a measurement of how far apart the notes are vertically on the staff, regardless of what accidentals are involved.

Example 1-19

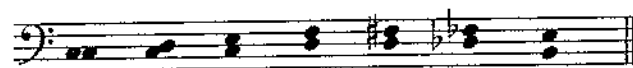

1 2 3 3 3 3 4 (etc.)

In talking about intervals, we use the terms **unison** instead of 1, and **octave** (8ve) instead of 8. We also say 2nd instead of “two,” 3rd instead of “three,” and so on. Intervals smaller than an 8ve are called **simple intervals**, whereas larger intervals (including the 8ve) are called **compound intervals**.

It is important to notice in Example 1-19 that the harmonic interval of a 2nd is notated with the top note offset a little to the right of the bottom note. Accidentals are offset in the same way for harmonic intervals of a 2nd, 3rd, or 4th, if both notes require an accidental.

Self-Test 1-4

(Answers begin on page 604.)

Provide the numerical names of the intervals by using the numbers 1 through 8.

Exercise 1-4 See Workbook.

Perfect, Major, and Minor Intervals

One way to begin learning the modifiers for intervals is by relating them to the intervals contained in the major scale, specifically the intervals from $\hat{1}$ up to the other scale degrees. This method can then be applied in any context, whether or not the major scale is actually being used.

The term **perfect** (abbreviated P) is a modifier used only in connection with unisons, 4ths, 5ths, 8ves, and their compounds (11ths, and so on). As Example 1-20 illustrates, a P1, P4, P5, and P8 can all be constructed by using $\hat{1}$ in the major scale as the *bottom* note.

Example 1-20

If we want to spell one of these intervals above $E\flat$, for example, we need only to think of scale steps $\hat{1}$, $\hat{4}$, and $\hat{5}$ of the $E\flat$ major scale. If the bottom note does not commonly serve as $\hat{1}$ of a major scale (such as $D\sharp$), remove the accidental temporarily, spell the interval, and then apply the accidental to both notes (Ex. 1-21).

Example 1-21

P5 above P5 above P5 above
 $D\sharp = ?$ $D\flat = A\flat$ $D\sharp = A\sharp$

The modifiers **major** and **minor** are used only in connection with 2nds, 3rds, 6ths, and 7ths. The intervals formed by $\hat{1}-\hat{2}$, $\hat{1}-\hat{3}$, $\hat{1}-\hat{6}$, and $\hat{1}-\hat{7}$ in the major scale are all major intervals, as Example 1-22 illustrates.

Example 1-22

$\hat{1} - \hat{2}$ $\hat{1} - \hat{3}$ $\hat{1} - \hat{6}$ $\hat{1} - \hat{7}$
 M2 M3 M6 M7

If a major interval is made a half step smaller without altering its numerical name, it becomes a minor interval (Ex. 1-23). Notice that you can make an interval smaller by lowering the top note or raising the bottom note.

Example 1-23

M2 m2 M3 m3 M6 m6 M7 m7

Self-Test 1-5

(Answers begin on page 604.)

A. All the intervals that follow are unisons, 4ths, 5ths, or 8ves. Put "P" in the space provided *only* if the interval is a perfect interval.

$\frac{1}{1} \quad \frac{5}{2} \quad \frac{4}{3} \quad \frac{1}{4} \quad \frac{5}{5} \quad \frac{8}{6} \quad \frac{4}{7} \quad \frac{5}{8} \quad \frac{4}{9} \quad \frac{5}{10} \quad \frac{8}{10}$

B. All the intervals that follow are 2nds, 3rds, 6ths, or 7ths. Write "M" or "m" in each space, as appropriate.

$\frac{3}{1} \quad \frac{6}{2} \quad \frac{7}{3} \quad \frac{2}{4} \quad \frac{6}{5} \quad \frac{2}{6} \quad \frac{3}{7} \quad \frac{7}{8} \quad \frac{6}{9} \quad \frac{2}{10}$

C. Notate the specified intervals above the given notes.

$\frac{m2}{1} \quad \frac{P4}{2} \quad \frac{M6}{3} \quad \frac{m3}{4} \quad \frac{P5}{5} \quad \frac{m6}{6} \quad \frac{P8}{7} \quad \frac{M2}{8} \quad \frac{M7}{9} \quad \frac{P4}{10}$
 $\frac{M3}{11} \quad \frac{P5}{12} \quad \frac{m7}{13} \quad \frac{m2}{14} \quad \frac{M6}{15} \quad \frac{P5}{16} \quad \frac{P8}{17} \quad \frac{M7}{18} \quad \frac{M3}{19} \quad \frac{m7}{20}$

Exercise 1-5 See Workbook.

Augmented and Diminished Intervals

If a perfect or a major interval is made a half step larger without changing the numerical name, the interval becomes **augmented** (abbreviated +). If a perfect or a minor interval is made a half step smaller without changing its numerical name, it becomes **diminished** (abbreviated °). These relationships are summarized as follows:

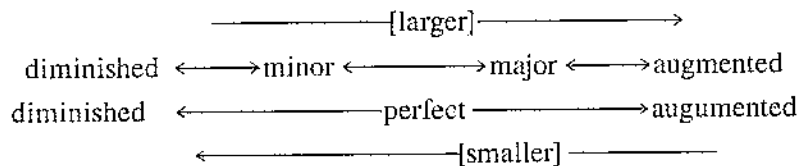

There is no such thing as a diminished unison. Doubly augmented and doubly diminished intervals are possible, but they seldom occur. **Tritone** is a term used for the +4 or its enharmonic equivalent, the °5.

Inversion of Intervals

Descending intervals, especially large ones, are often easier to spell and identify through the use of **interval inversion**. We invert an interval by putting the bottom pitch above the top one; for example, the interval D-A inverts to A-D. When we invert an interval, the new numerical name is always different from the old one. The new numerical name can be calculated by subtracting the old numerical name from 9.

Constant value of 9	9	9	9	9	9	9
Minus old numeric name	<u>-2</u>	<u>-3</u>	<u>-4</u>	<u>-5</u>	<u>-6</u>	<u>-7</u>
Equals new numeric name	7	6	5	4	3	2

You can see that an inverted 2nd becomes a 7th, a 3rd becomes a 6th, and so on (Ex. 1-24).

Example 1-24

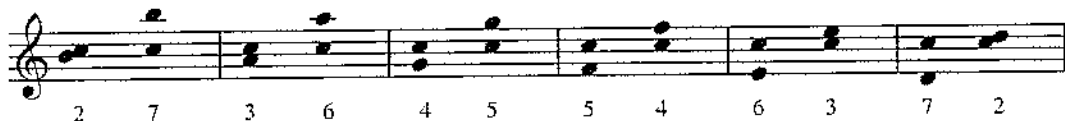

The modifier also changes when an interval is inverted, with the exception of perfect intervals.

Old modifier	m	M	P	+	°
New modifier	M	m	P	°	+

As an example of the usefulness of inversion, suppose you wanted to know what note lies a m6 below G3. Invert the m6 down to a M3 up, as in Example 1-25, transpose the B3 down an 8ve, and you find that the answer is B2.

Example 1-25



Fluency with intervals, as with scales, is necessary for any serious musician and will provide a solid foundation for your further study. As you did with scales, you will benefit from finding out how various intervals sound and feel on a musical instrument.

One exercise you can do (you can think of others) is to write out the notes of the chromatic scale in random order. Include each black key twice—once as a sharped note and once as a flatted note. Then play some interval above and below each note. Work for speed, using your ear to correct yourself.

Consonant and Dissonant Harmonic Intervals

In tonal music, some harmonic intervals are considered to be consonant, whereas others are considered to be dissonant. The terms **consonant** and **dissonant** can be defined roughly as meaning pleasing to the ear and not pleasing to the ear, respectively, but these are very dependent on context. Some of the most exciting moments in tonal music involve dissonance, which is certainly not displeasing in that context, but the dissonances resolve eventually to the consonances that give them meaning. As you can imagine, this is a complex subject, and it is one with which much of this book is concerned.

For now it will suffice to say that major and minor 3rds and 6ths and perfect 5ths and 8ves are consonant. All other harmonic intervals, including all augmented and diminished intervals, are dissonant. An exception is the P4, which is considered dissonant only when it occurs above the lowest voice (also called the **bass**, in both vocal and instrumental music).

CHECKPOINT

1. What is the term for an interval in which the notes are played in succession instead of simultaneously?
2. Is there such a thing as a m5? A P6?
3. A perfect interval made a half step smaller without changing its numerical name becomes _____.
4. A $\text{^}5$ inverted becomes a _____.
5. Intervals that are relatively displeasing to the ear are classified as _____.

Self-Test 1-6

(Answers begin on page 604.)

- A. Most of the following intervals are either augmented or diminished. Label each interval.

1 2 3 4 5 6 7 8 9 10

B. Label what each interval becomes when it is inverted.

- | | |
|---------------------|---------------------|
| 1. P4 becomes _____ | 5. °5 becomes _____ |
| 2. M7 becomes _____ | 6. m2 becomes _____ |
| 3. +2 becomes _____ | 7. m6 becomes _____ |
| 4. M3 becomes _____ | 8. +6 becomes _____ |

C. Notate the specified interval *below* the given note. (You may find it helpful to invert the interval first in some cases.)

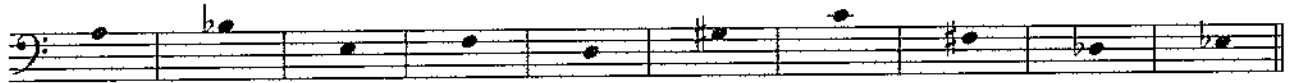

- | | | | | | | | | | |
|----------------|----------------|----------------|----------------|----------------|----------------|----------------|----------------|----------------|-----------------|
| $\frac{P5}{1}$ | $\frac{m7}{2}$ | $\frac{m3}{3}$ | $\frac{M6}{4}$ | $\frac{+4}{5}$ | $\frac{M7}{6}$ | $\frac{+5}{7}$ | $\frac{m6}{8}$ | $\frac{M2}{9}$ | $\frac{°7}{10}$ |
|----------------|----------------|----------------|----------------|----------------|----------------|----------------|----------------|----------------|-----------------|

D. Label each interval in this melody (from Wagner's *Götterdämmerung*).



E. Beneath each of the following harmonic intervals, indicate whether it is consonant ("c"), dissonant ("d"), or dissonant only if the bass has the bottom note of the interval ("d bass").

	1. m7	2. P1	3. P8	4. °7	5. m6
c	_____	_____	_____	_____	_____
d	_____	_____	_____	_____	_____
d bass	_____	_____	_____	_____	_____
	6. M2	7. P5	8. M3	9. +2	10. P4
c	_____	_____	_____	_____	_____
d	_____	_____	_____	_____	_____
d bass	_____	_____	_____	_____	_____

Exercise 1-6 See Workbook.

Summary

Pitch in music refers to the highness or lowness of a sound. Particular pitches are named by using the **musical alphabet**, consisting of the letters A through G, at which point the alphabet starts over. From one letter up or down to its next occurrence is called an **octave**, whereas the space from any C up to the next B is called an **octave register**. Octave registers are numbered, with the lowest C on the piano keyboard designated as C1. The C nearest the middle of the piano keyboard is called **middle C**, or C4.

Pitches are notated on the **staff**, an arrangement of five lines and four spaces that can be extended through the use of **ledger lines**. A staff always begins with one of several **clefs**, which determine exactly what pitch is represented by each line or space. A **grand staff** consists of two staves joined by a brace, with a treble clef on the top staff and a bass clef on the bottom.

The **major scale** consists of two identical tetrachords that have a particular arrangement of **whole steps** and **half steps**. Most major scales also have a **parallel minor scale** that begins on the same note but that lowers scale degrees $\hat{3}$, $\hat{6}$, and $\hat{7}$ by a half step. This form of the minor is called the **natural minor scale**. The **harmonic minor scale** lowers only scale degrees $\hat{3}$ and $\hat{6}$ of its parallel major, whereas the **melodic minor scale** lowers scale degree $\hat{3}$ when ascending and scale degrees $\hat{3}$, $\hat{6}$, and $\hat{7}$ when descending.

Every scale has an associated **key signature**, consisting of zero to seven sharps or flats arranged in a particular way on the staff. There are 15 key signatures in all, with one major and one minor scale associated with each. Major and minor keys that share the same key signature are said to be **relative keys**, whereas those that share the same starting note are called **parallel keys**. The notes of a scale are all assigned **scale degree names**, which vary only slightly between major and minor. **Enharmonic notes** or keys sound the same but are spelled differently. To **transpose** music means to play it in another key.

The difference between any two pitches is called an **interval**. A **harmonic interval** separates pitches that are sounded simultaneously, whereas a **melodic interval** separates pitches that are sounded in succession. Intervals are defined by means of a numerical name and a modifier that precedes it. These modifiers include the terms **perfect**, **major**, **minor**, **augmented**, and **diminished**. To **invert** an interval, put the lower note above the upper one (or the reverse). The numerical name and modifier of an inverted interval can be predicted using the method explained in this chapter.

Consonant intervals include major and minor 3rds and 6ths, the P5, and the P8. The P4 is usually consonant, unless it occurs above the lowest voice.

Variations



For additional review and practice, please see Chapter 1 on our website at www.mhhe.com/tonalharmony6.

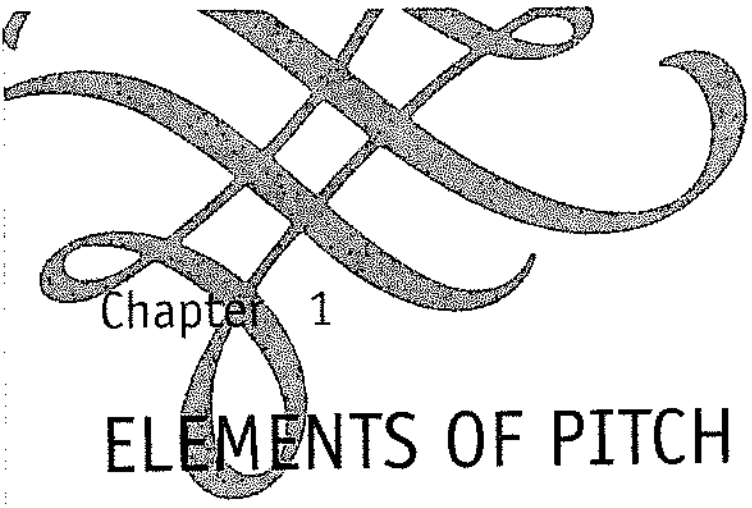

Part I

Fundamentals

Chapter 1

ELEMENTS OF PITCH

EXERCISE 1-1

A. Name the pitches in the blanks provided, using the correct octave register designations.

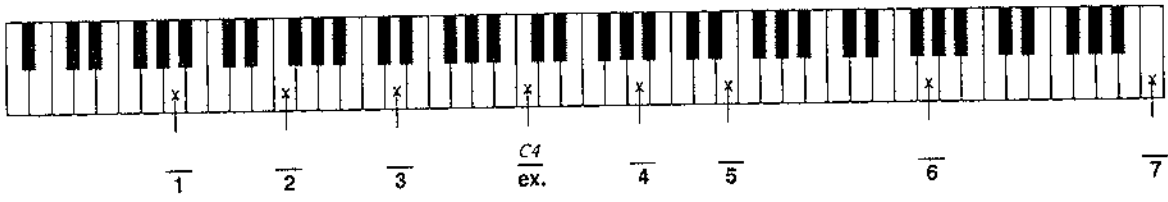

B. Notate the indicated pitches on the staff in the correct octave.

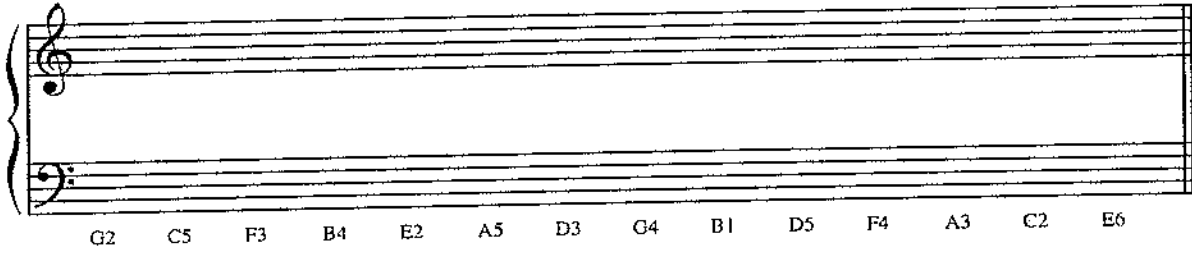

There is no
page 2.

EXERCISE 1-2

A. Notate the specified scales using accidentals, not key signatures. Show the placement of whole and half steps, as in the example.

C major Ab major
 G major Cb major
 B major Gb major
 Eb major D major

B. Identify these major key signatures.

C major 1 major 2 major 3 major 4 major 5 major 6 major 7 major
ex. 1 2 3 4 5 6 7

C. Notate the specified key signatures.

Ab major E major F major C major
 Gb major G major Eb major C# major

D. Fill in the blanks.

<i>Key signature</i>	<i>Name of key</i>	<i>Key signature</i>	<i>Name of key</i>
1. _____	D \flat major	8. seven flats	_____ major
2. _____	G major	9. _____	F major
3. five sharps	_____ major	10. _____	E major
4. _____	E \flat major	11. two sharps	_____ major
5. two flats	_____ major	12. three flats	_____ major
6. three sharps	_____ major	13. _____	G \flat major
7. _____	C \sharp major	14. six sharps	_____ major

E. Fill in the blanks, using the example as a model.

	<i>Major Key</i>	<i>Key Signature</i>	<i>Scale Degree</i>	<i>Is This Note</i>
Ex.	C	0 \sharp /0 \flat	5	G
1.	E	_____	3	_____
2.	_____	2 \sharp	_____	C \sharp
3.	_____	_____	4	E \flat
4.	G \flat	_____	_____	E \flat
5.	_____	3 \sharp	2	_____
6.	_____	G \sharp	_____	C \sharp

EXERCISE 1-3

A. Notate the specified scales using accidentals, not key signatures. The melodic minor should be written both ascending and descending.

c (natural) e (harmonic)

b (natural) a^b (harmonic)

g (melodic)

a[#] (natural) d (harmonic)

d[#] (melodic)

B. Identify the type of each scale as major, natural minor, harmonic minor, or melodic minor. Any melodic minor scales will be shown in the ascending version only.

1. _____ 2. _____

3. _____ 4. _____

5. _____ 6. _____

C. Identify these minor key signatures.



$\frac{a}{\text{ex.}}$ minor $\frac{1}{1}$ minor $\frac{2}{2}$ minor $\frac{3}{3}$ minor $\frac{4}{4}$ minor $\frac{5}{5}$ minor $\frac{6}{6}$ minor $\frac{7}{7}$ minor

D. Notate the specified minor key signatures.



$e\flat$ minor $c\sharp$ minor g minor a minor



e minor $a\flat$ minor $d\sharp$ minor f minor

E. Fill in the blanks.

<i>Key signature</i>	<i>Name of key</i>	<i>Key signature</i>	<i>Name of key</i>
1. three sharps	$f\sharp$ minor	8. _____	g minor
2. _____	$e\flat$ minor	9. two sharps	_____ minor
3. _____	$c\sharp$ minor	10. seven flats	_____ minor
4. five flats	_____ minor	11. _____	e minor
5. _____	a minor	12. one flat	_____ minor
6. four flats	_____ minor	13. _____	c minor
7. seven sharps	_____ minor	14. _____	$g\sharp$ minor

EXERCISE 1-4

A. Provide the numerical names of the intervals by using the numbers 1 through 8.

A grand staff with two staves. The top staff has a treble clef and the bottom staff has a bass clef. The key signature has one flat (B-flat). The notes are: Treble: G4, A4, B4, C5 (with a flat), D5, E5, F5, G5. Bass: G3, A3, B3, C4, D4, E4, F4, G4.

1 2 3 4 5 6 7 8 9 10 11 12 13 14 15

EXERCISE 1-5

A. All the following intervals are 4ths, 5ths, unisons, or octaves. Put a "P" in the space provided *only* if the interval is a perfect interval.

A single staff with a treble clef. The key signature has one flat (B-flat). The notes are: G4, A4, B4, C5, D5, E5, F5, G5, A5, B5, C6.

1⁴ 2⁵ 3⁸ 4⁴ 5¹ 6⁵ 7⁴ 8⁵ 9⁴ 10¹

A single staff with a bass clef. The key signature has one flat (B-flat). The notes are: G3, A3, B3, C4, D4, E4, F4, G4, A4, B4, C5.

11⁵ 12⁵ 13⁸ 14⁵ 15⁴ 16¹ 17⁴ 18⁸ 19⁵ 20⁴

B. All the following intervals are 2nds, 3rds, 6ths, or 7ths. Put an "M" or an "m" in each space, as appropriate.

A single staff with a bass clef. The key signature has one flat (B-flat). The notes are: G3, A3, B3, C4, D4, E4, F4, G4, A4, B4, C5.

1⁶ 2³ 3² 4⁷ 5³ 6⁷ 7⁶ 8² 9³ 10⁷

A single staff with a treble clef. The key signature has one flat (B-flat). The notes are: G4, A4, B4, C5, D5, E5, F5, G5, A5, B5, C6.

11⁶ 12³ 13³ 14⁷ 15⁶ 16³ 17² 18⁷ 19⁶ 20⁷

21 2 22 3 23 2 24 6 25 7 26 2 27 7 28 6 29 3 30 2

C. Notate the specified intervals above the given notes.

P4 1 m3 2 m6 3 M2 4 P4 5 P5 6 m2 7 P5 8 M7 9 m7 10

M3 11 P8 12 M6 13 m7 14 M3 15 M7 16 P8 17 P5 18 M6 19 m2 20

m3 21 M2 22 M7 23 M3 24 M6 25 m7 26 P4 27 M7 28 M6 29 m2 30

M6 31 M3 32 m3 33 M3 34 P5 35 m2 36 m6 37 m7 38 M7 39 M2 40

m6 41 M2 42 P4 43 m3 44 m7 45 P5 46 m6 47 P5 48 M7 49 m2 50

P5 51 P4 52 m3 53 m7 54 M2 55 P4 56 M6 57 m6 58 m2 59 M3 60

EXERCISE 1-6

A. Most of the intervals that follow are either augmented or diminished. Name each interval.

1 2 3 4 5 6 7 8 9 10

11 12 13 14 15 16 17 18 19 20

B. Label what each interval becomes when it is inverted.

- | | |
|---------------------|---------------------|
| 1. m3 becomes _____ | 5. M2 becomes _____ |
| 2. +5 becomes _____ | 6. +4 becomes _____ |
| 3. M6 becomes _____ | 7. P5 becomes _____ |
| 4. °7 becomes _____ | 8. m7 becomes _____ |

C. Notate the specified interval *below* the given note. (You might find it helpful to invert the interval first in some cases.)

M7 1 P4 2 m6 3 +2 4 m7 5 M3 6 +6 7 °5 8 +4 9 M6 10

m2 11 M3 12 +6 13 M2 14 °5 15 m3 16 °7 17 P4 18 +2 19 +4 20

$\frac{m7}{21}$ $\frac{P5}{22}$ $\frac{m3}{23}$ $\frac{m2}{24}$ $\frac{P4}{25}$ $\frac{M7}{26}$ $\frac{m2}{27}$ $\frac{^{\circ}5}{28}$ $\frac{M2}{29}$ $\frac{+6}{30}$
 $\frac{m6}{31}$ $\frac{P4}{32}$ $\frac{M3}{33}$ $\frac{P5}{34}$ $\frac{+2}{35}$ $\frac{m3}{36}$ $\frac{P5}{37}$ $\frac{^{\circ}7}{38}$ $\frac{M2}{39}$ $\frac{M6}{40}$

D. Label each interval in this melody (from Wagner's *Götterdämmerung*).

1 2 3 4 5 6 7 8 9
 10 11 12 13 14 15 16 17 18 19 20 21 22 23 24

E. Beneath each harmonic interval that follows, indicate whether it is consonant ("c"), dissonant ("d"), or dissonant only if the bass has the bottom note of the interval ("d bass").

	1. m3	2. M7	3. $^{\circ}6$	4. P5	5. M6
c	_____	_____	_____	_____	_____
d	_____	_____	_____	_____	_____
d bass	_____	_____	_____	_____	_____
	6. $^{\circ}5$	7. P4	8. P8	9. m2	10. M3
c	_____	_____	_____	_____	_____
d	_____	_____	_____	_____	_____
d bass	_____	_____	_____	_____	_____